

INCREMENTAL X-Y CALIBRATION SLIDE



EXTREMELY LOW PROFILE HEIGHT: 118mm

FULLY ENCLOSED, MATCH GROUND ACME SCREW ELIMINATES BACKLASH

STEEL OR ALUMINUM CONSTRUCTION

CORROSION RESISTANT COATING

LOAD CARRYING CAPABILITY: 500 lbf. OFFSET LOAD 500 lbf.-ft

.25mm INCREMENTAL INDEX

APPLICATIONS: PIERCE UNITS, WELD GUNS, CLINCH UNITS

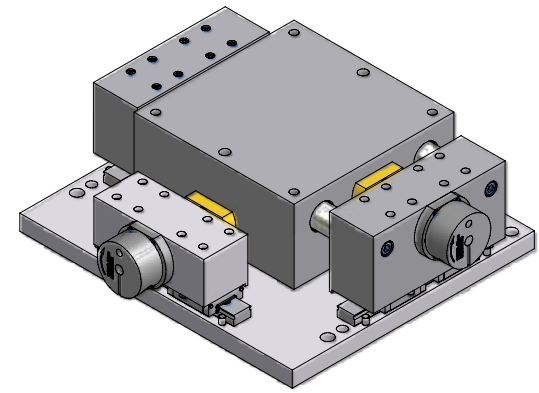
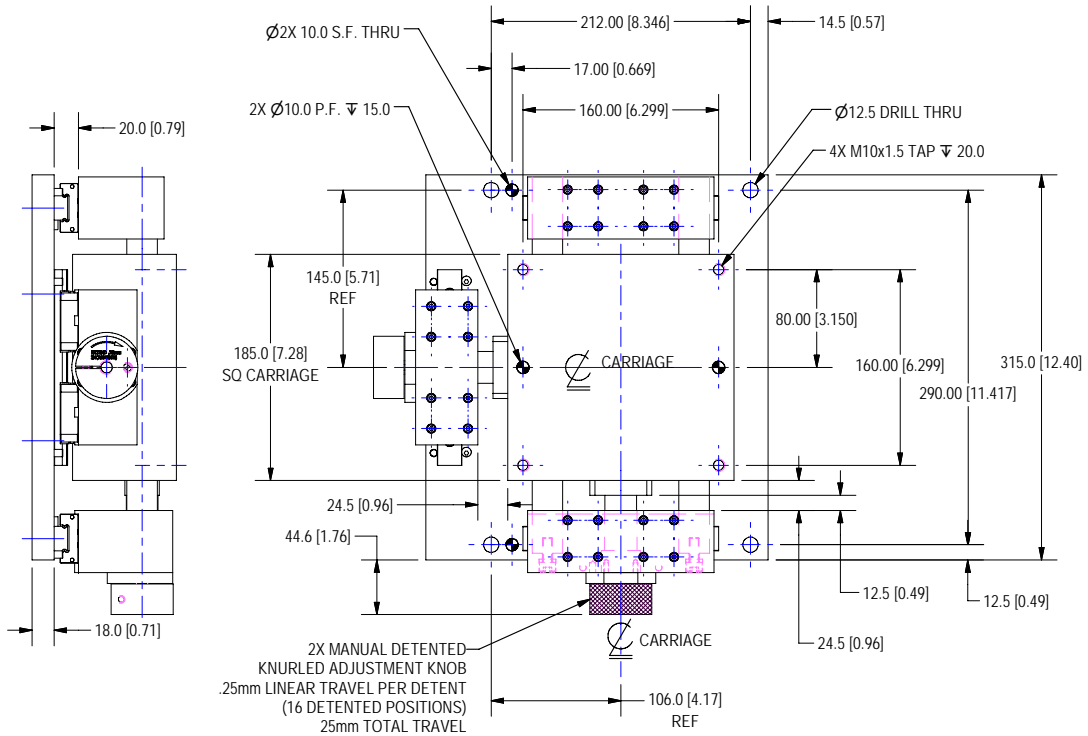

NOTE:
 MAXIMUM MOMENT ABOUT C.L. OF CARRIAGE = 500 lbf.ft.

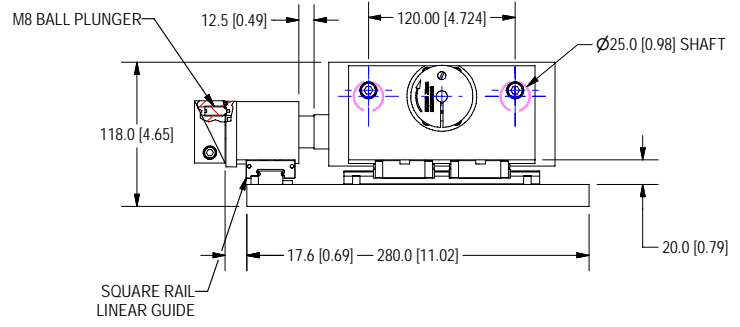

PRELIMINARY

ALUMINUM PROTOTYPE WEIGHT 50#

UNITS ARE MILLIMETERS (i.e.X.XXmm [x.xxx"])
 DO NOT SCALE DRAWING

		TOOL NAME		2 AXIS MANUAL DETENT SLIDE	
		TEMPLATE			
DATE	STATUS	DRAWN BY	DATE	CHECKED BY	ENG. APPROVAL
9/10/2008	Quick Change	MP	14	SCA	FILE NAME PROTOTYPE