

BLADE TOLERANCE:  
 $\text{Ø}18 \text{ H}7$  (18.018/18.000)

PIN TOLERANCE  
 $\text{Ø}12 \text{ g}6$  (11.994/11.983)

MATL:  
 C86300 BRONZE ALLOY  
 w/ SOLID LUBRICANT PLUGS

<b>WEKER</b> BEARING COMPANY			
TOOL NAME			
SELF LUBE CLAMP PIVOT BEARING			
TEMPLATE			
DRAWN BY	DATE	CHK'D BY	ENG APPROVAL
GSK	5/8/2008	DK	
SCALE	NONE	FILE NAME	S01115012018019

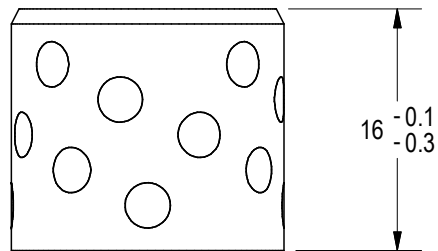
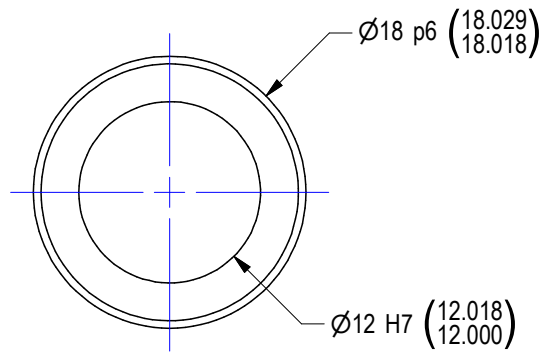

BLADE TOLERANCE:  
 $\varnothing 18$  H7 (18.018/18.000)

PIN TOLERANCE  
 $\varnothing 12$  g6 (11.994/11.983)

MATL:  
 C86300 BRONZE ALLOY  
 w/ SOLID LUBRICANT PLUGS

			
TOOL NAME			
SELF LUBE CLAMP PIVOT BEARING			
TEMPLATE			
DRAWN BY	DATE	CHK'D BY	ENG APPROVAL
GSK	5/8/2008	DK	
SCALE	NONE	FILE NAME	S01115012018016